

**SINGLE-STAGE, 9-SPEED
ECM ULTRA-LOW NOX GAS FURNACE
80% AFUE**

HEATING INPUT : 40,000 - 80,000 BTU/H



■ **Contents**

Nomenclature.....	2
Product Specifications.....	3
Dimensions	4
Airflow Specifications.....	5
Wiring Diagram.....	8
Accessories	9

■ **Standard Features**

- Heavy-duty stainless-steel dual-diameter tubular heat exchanger
- Single-stage gas valve
- Durable Hot-surface igniter
- Quiet, modulating draft inducer
- Self-diagnostic control board with constant memory fault history output to a 3-digit 7 segment LED display and push buttons
- Color-coded low-voltage terminals
- Energy-efficient multi-speed (9-speed tap) ECM blower motor
- Multiple continuous fan speed options offer quiet air circulation
- All models comply with CA Low NOx standards
- All Ultra-Low NOx DM80SN-U models comply with the 14 ng/J emission limit specified in the South Coast Air Quality Management District (SCAQMD) Rule 1111 and San Joaquin Valley Air Pollution Control District (SJVAPCD) Rule 4905. Learn more at www.aqmd.gov and www.valleyair.org

■ **Cabinet Features**

- Multi-position installation:
DM80SN-U: Upflow, horizontal left or right
- Cabinet air leakage (QLeak) ≤ 2%
- Convenient left or right connection for gas and electrical service
- Heavy-gauge steel cabinet with durable baked-enamel finish
- Foil faced insulated heat exchanger



* Complete warranty details available from your local dealer or at www.daikincomfort.com. To receive the Lifetime Heat Exchanger Limited Warranty (good for as long as you own your home), the 6-Year Unit Replacement Limited Warranty and the 12-Year Parts Limited Warranty, online registration must be completed within 60 days of installation. Additional requirements for annual maintenance are required for the Unit Replacement Limited Warranty. Online registration and some of the additional requirements are not required in California or Quebec.

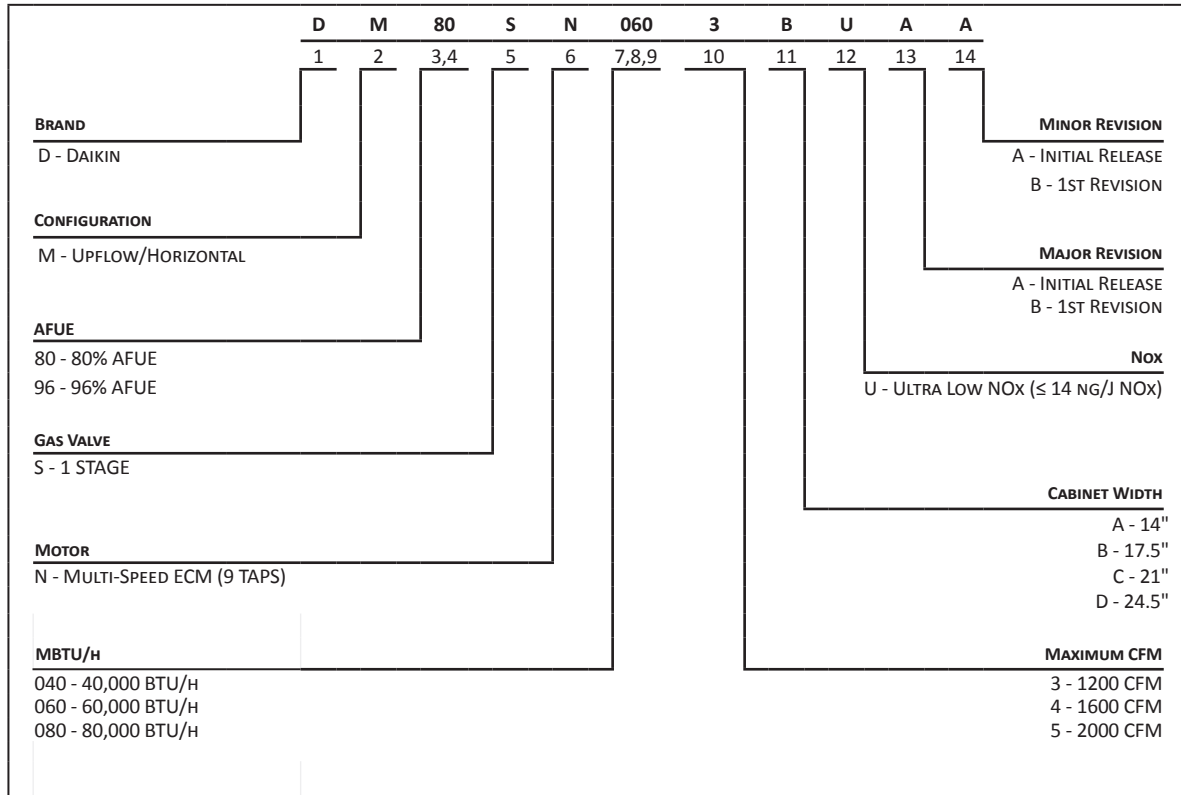

	DM80SN 0403AU*	DM80SN 0603AU*	DM80SN 0604BU*	DM80SN 0804BU*	DM80SN 0805CU*
HEATING CAPACITY					
Input ¹	40,000	60,000	60,000	80,000	80,000
Natural Gas Output ¹	32,000	48,000	48,000	64,000	64,000
AFUE ²	80	80	80	80	80
Available AC @ 0.5" ESP	1 - 3	1 - 3	1.5 - 4	1.5 - 4	2.5 - 5
Temperature Rise Range (°F)	25 - 55	20 - 50	20 - 50	35 - 65	35 - 65
CIRCULATOR BLOWER					
Size (D x W)	10" x 6"	10" x 6"	10" x 8"	10" x 8"	10" x 10"
Horsepower	½	½	¾	¾	1
No. of Speeds	9	9	9	9	9
Vent Diameter ³	4"	4"	4"	4"	4"
No. of Burners	2	3	3	4	4
ELECTRICAL DATA					
Min. Circuit Ampacity ⁴	8.7	8.7	12.5	12.5	12.7
Max. Overcurrent Device (amps) ⁵	15	15	15	15	15
SHIP WEIGHT (LBS)	86	90	100	108	116

¹ Natural Gas BTU/h; for altitudes 0-4500' Only

² DOE AFUE based upon Isolated Combustion System (ICS)

³ Vent and combustion air diameters may vary depending upon vent length. Refer to the latest editions of the National Fuel Gas Code NFPA 54/ANSI Z223.1 (in the USA) and the Canada National Standard of Canada, CAN/CSA B149.1 and CAN/CSA B142.2 (in Canada).

⁴ Minimum Circuit Ampacity = (1.25 x Circulator Blower Amps) + ID Blower amps. Wire size should be determined in accordance with National Electrical Codes. Extensive wire runs will require larger wire sizes.

⁵ Maximum Overcurrent Protection Device refers to maximum recommended fuse or circuit breaker size. May use fuses or HACR-type circuit breakers of the same size as noted.

NOTES

- All furnaces are manufactured for use on 115 VAC, 60 Hz, single-phase electrical supply.
- Gas Service Connection ½" FPT
- Important: Size fuses and wires properly and make electrical connections in accordance with the National Electrical Code and/or all existing local codes.

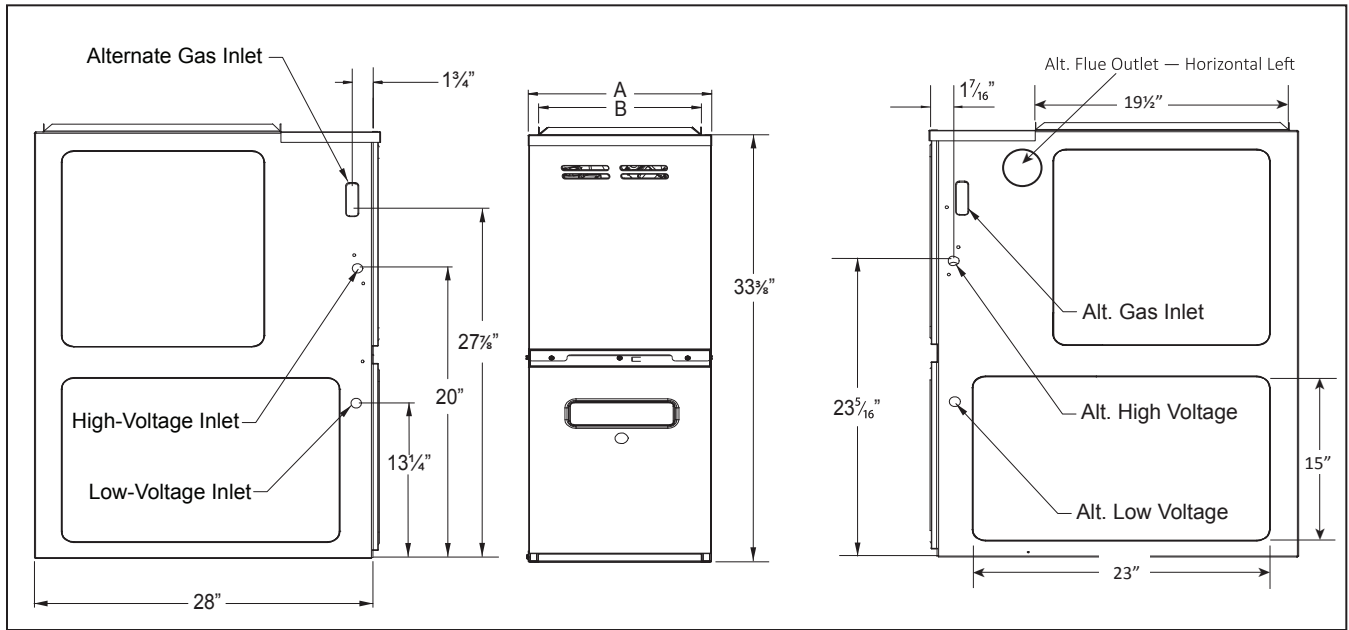

MODEL	A	B
DM80SN0403AU*	14"	12 1/2"
DM80SN0603AU*	14"	12 1/2"
DM80SN0604BU*	17 1/2"	16"
DM80SN0804BU*	17 1/2"	16"
DM80SN0805CU*	21"	19 1/2"

NOTES

- Line voltage wiring can enter through the right or left side of furnace.
Low-voltage wiring can enter through the right or left side of furnace.
- Installer must supply the following gas line fittings, according to which entrance is used:
Left: One 2" pipe nipple; one 90° elbow; straight pipe; one ground joint union
Right: Five 90° elbow; one ground joint union; various pipe nipples

MINIMUM CLEARANCES TO COMBUSTIBLE MATERIALS

SIDES	REAR	FRONT	BOTTOM	VENT		TOP
				SW	B	
1"	0"	3"	C	6"	1"	1"

C = If placed on combustible floor, the floor MUST be wood ONLY.

NOTES

- For servicing or cleaning, a 24" front clearance is recommended.
- Unit connections (electrical, flue, and drain) may necessitate greater clearances than the minimum clearances listed above.
- In all cases, accessibility clearance must take precedence over clearances from the enclosure where accessibility clearances are greater.
- Refer to the appropriate USA and Canadian codes:
 - In the USA: the National Fuel Gas Code NFPA 54 / ANSI Z223.1
 - In Canada: the Canada National Standard of Canada, CAN/CSA B149.1 and CAN/CSA B142.2

MODEL	THERMOSTAT CALL	TAP #	EXTERNAL STATIC PRESSURE, (INCHES WATER COLUMN)							
			0.1	0.2	0.3	0.4	0.5	0.6	0.7	0.8
			CFM	CFM	CFM	CFM	CFM	CFM	CFM	CFM
DM80SN 0403AU*	Y1 / Y2 / G	F01	590	540	483	429	369	311	247	203
		F02	690	643	597	547	498	443	389	343
		F03	750	702	660	618	572	525	477	421
		F04	876	832	794	758	716	678	641	598
		F05^	927	881	841	806	771	734	698	662
		F06	1058	1015	976	945	915	881	849	818
		F07	1116	1071	1036	1003	975	943	919	884
		F08^^	1238	1192	1158	1124	1098	1070	1044	1016
		F09	1398	1357	1320	1293	1269	1239	1216	1194
DM80SN 0603AU*	Y1 / Y2 / G	F01	587	542	490	437	382	318	266	207
		F02	685	638	590	543	498	448	392	339
		F03	856	814	774	732	693	657	622	581
		F04^	937	892	855	819	786	752	715	684
		F05	1060	1017	981	950	921	886	856	828
		F06^^	1108	1068	1033	1003	972	942	914	882
		F07	1274	1233	1203	1174	1146	1118	1089	1065
		F08	1374	1340	1306	1278	1254	1227	1201	1179
		F09	1437	1395	1362	1332	1305	1278	1253	1228
DM80SN 0604AU*	Y1 / Y2 / G	F01	836	774	711	655	596	523	456	397
		F02	1274	1228	1188	1147	1107	1064	1027	990
		F03	1295	1256	1214	1181	1140	1100	1062	1024
		F04	1385	1337	1301	1260	1222	1186	1149	1114
		F05	1454	1407	1372	1353	1325	1291	1255	1219
		F06^	1528	1485	1438	1409	1383	1349	1317	1285
		F07	1619	1579	1551	1523	1495	1463	1430	1402
		F08^^	1746	1697	1667	1642	1617	1593	1570	1540
		F09	1772	1735	1698	1674	1645	1622	1598	1574
DM80SN 0804BU*	Y1 / Y2 / G	F01	722	658	599	534	458	386	330	268
		F02	1270	1223	1179	1139	1105	1066	1029	996
		F03	1304	1254	1212	1173	1135	1104	1069	1032
		F04	1367	1318	1277	1236	1199	1169	1135	1102
		F05^	1473	1429	1386	1355	1320	1289	1258	1224
		F06	1560	1518	1476	1441	1409	1382	1350	1321
		F07	1647	1605	1562	1531	1497	1467	1440	1408
		F08^^	1720	1710	1674	1642	1611	1581	1553	1527
		F09	1796	1759	1721	1687	1655	1628	1604	1578
DM80SN 0805CU*	Y1 / Y2 / G	F01	1280	1228	1178	1134	1086	1036	986	936
		F02	1401	1356	1313	1273	1234	1190	1145	1099
		F03	1593	1550	1512	1475	1436	1399	1360	1319
		F04	1706	1662	1621	1586	1550	1515	1479	1444
		F05^	1821	1775	1736	1703	1669	1636	1605	1576
		F06	1836	1793	1757	1721	1689	1659	1628	1592
		F07	1932	1888	1855	1825	1794	1762	1733	1701
		F08^^	2184	2143	2110	2072	2048	2017	1989	1959
		F09	2221	2178	2145	2109	2082	2053	2025	1992

Default speed is F01 for circulation for all models

^ Default Y1 speed

^^ Default Y2 speed

MODEL	THERMOSTAT CALL	TAP #	EXTERNAL STATIC PRESSURE, (INCHES WATER COLUMN)												
			0.1		0.2		0.3		0.4		0.5		0.6	0.7	0.8
			CFM	RISE	CFM	RISE	CFM	RISE	CFM	RISE	CFM	RISE	CFM	CFM	CFM
DM80SN 0403AU*	W/W1	F02	690	42	643	46	597	49	547	53	498	55	443	389	343
		F03^	750	39	702	42	660	45	618	48	572	52	525	477	421
		F04	876	34	832	36	794	37	758	39	716	41	678	641	598
		F05	927	32	881	34	841	35	806	37	771	38	734	698	662
		F06	1058	28	1015	29	976	30	945	31	915	32	881	849	818
		F07	1116	27	1071	28	1036	29	1003	30	975	30	943	919	884
DM80SN 0603AU*	W/W1	F05	1060	42	1017	44	981	45	950	47	921	48	886	856	828
		F06	1108	40	1068	42	1033	43	1003	44	972	46	942	914	882
		F07^	1274	35	1233	36	1203	37	1174	38	1146	39	1118	1089	1065
DM80SN 0604AU*	W/W1	F02	1274	35	1228	36	1188	37	1147	39	1107	40	1064	1027	990
		F03	1295	34	1256	35	1214	37	1181	38	1140	39	1100	1062	1024
		F04^	1385	32	1337	33	1301	34	1260	35	1222	36	1186	1149	1114
		F05	1454	31	1407	32	1372	32	1353	33	1325	34	1291	1255	1219
DM80SN 0804BU*	W/W1	F02^	1270	47	1223	48	1179	50	1139	52	1105	54	1066	1029	996
		F03	1304	45	1254	47	1212	49	1173	51	1135	52	1104	1069	1032
		F04	1367	43	1318	45	1277	46	1236	48	1199	49	1169	1135	1102
DM80SN 0805CU*	W/W1	F01	1280	46	1228	48	1178	50	1134	52	1086	55	1036	986	936
		F02^	1401	42	1356	44	1313	45	1273	47	1234	48	1190	1145	1099

^ Default Heat Speed

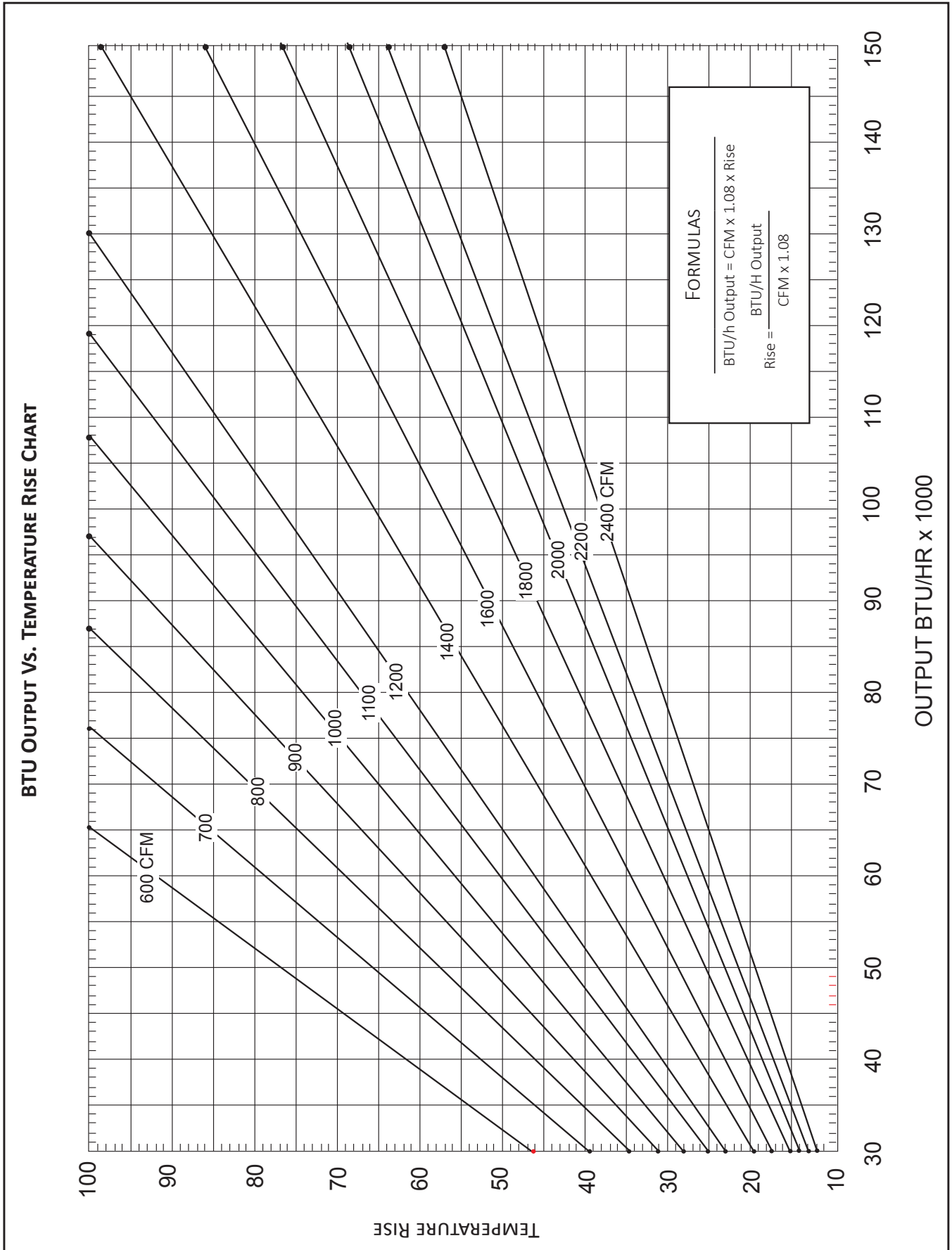

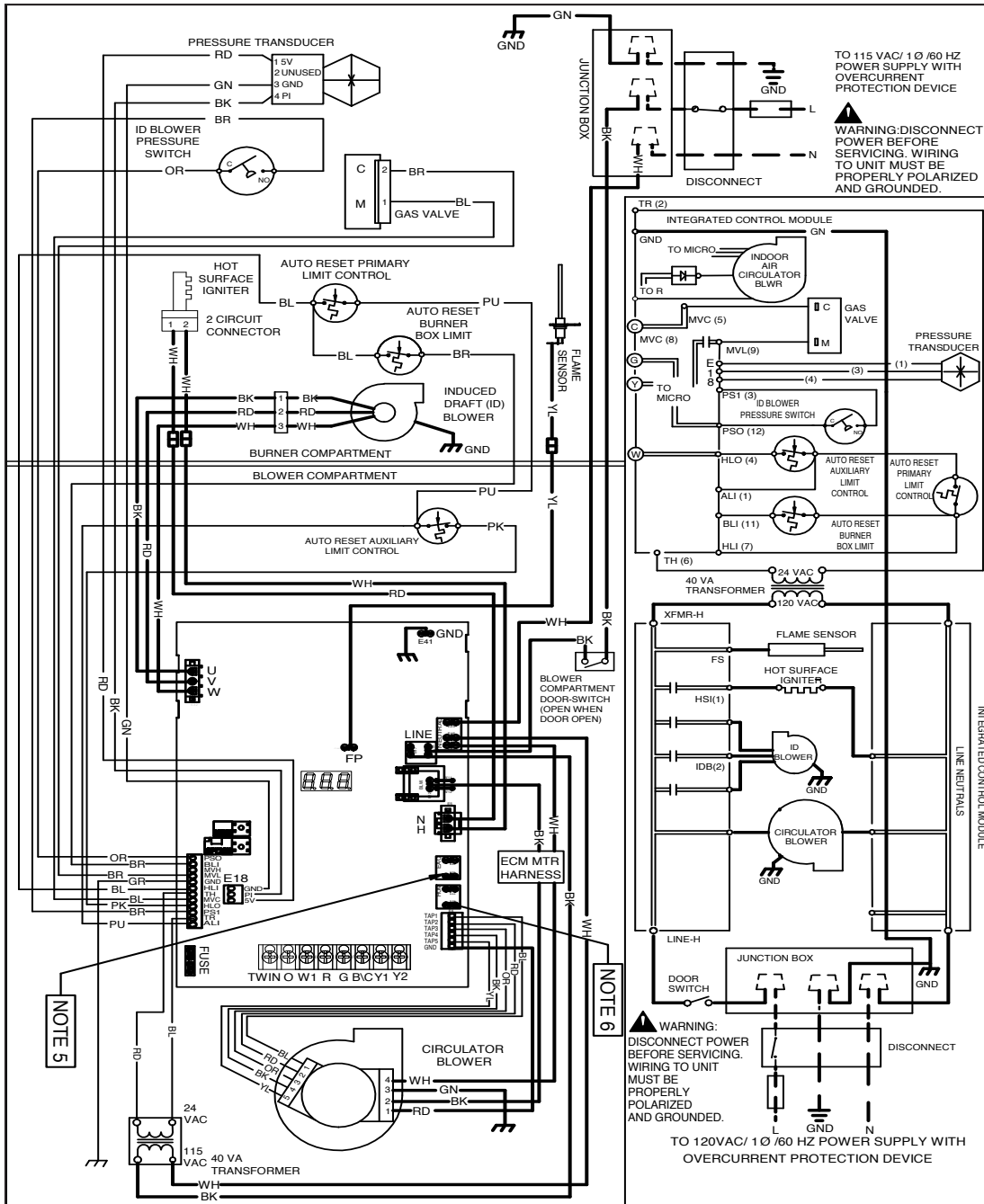

TO 115 VAC/ 1 Ø / 60 HZ POWER SUPPLY WITH OVERCURRENT PROTECTION DEVICE

WARNING-DISCONNECT POWER BEFORE SERVICING. WIRING TO UNIT MUST BE PROPERLY POLARIZED AND GROUNDED.

WARNING: DISCONNECT POWER BEFORE SERVICING. WIRING TO UNIT MUST BE PROPERLY POLARIZED AND GROUNDED.

TO 120VAC/ 1 Ø / 60 HZ POWER SUPPLY WITH OVERCURRENT PROTECTION DEVICE

NOTE 5

NOTE 6

Status & Fault (see installation manual for complete list of faults)	Seven Segment Display		
	Seg. 1	Seg. 2	Seg. 3
Idle	1	d	L
Continuous fan	F	A	n
Low Stage Cooling	1	A	C
High Stage Cooling	2	A	C
Gas Heat		g	H
HP Heat, Low Stage	1	H	P
HP Heat, High Stage	2	H	P
Defrost	d	F	t
Lockout Due to Excessive Retries Recycle	E	E	0
Pressure Switch Closed When Expected To Be Open	E	E	1
Pressure Switch Open When Expected To Be Closed	E	E	2
Open High Limit Switch	E	E	3
Flame Detected When No Flame Should Be Present	E	E	4
Open Fuse	E	E	5
Low Flame Signal	E	E	6
Ignitor Fault Or Ignitor Relay Fault	E	E	7
Reversed Line Polarity	E	E	A
Grounding Error	E	1	0
Internal Gas Valve Error	E	E	b
External Gas Valve Error	E	E	C
Aux Limit Switch Open	E	E	d
Burner Limit Switch Open	E	1	l

NOTES:

- MANUFACTURER'S SPECIFIED REPLACEMENT PARTS MUST BE USED WHEN SERVICING.
- IF ANY OF THE ORIGINAL WIRE AS SUPPLIED WITH THE FURNACE MUST BE REPLACED, IT MUST BE REPLACED WITH WIRING MATERIAL HAVING A TEMPERATURE RATING OF AT LEAST 105°C. USE COPPER CONDUCTORS ONLY.
- BLOWER SPEEDS SHOULD BE ADJUSTED BY INSTALLER TO MATCH THE INSTALLATION REQUIREMENTS SO AS TO PROVIDE THE CORRECT HEATING TEMPERATURE RISE AND THE CORRECT COOLING CFM.
- UNIT MUST BE PERMANENTLY GROUNDED AND CONFORM TO N.E.C. AND LOCAL CODES.
- EAC: NORMALLY OPEN CONTACTS FOR OPTIONAL ELECTRONIC AIR CLEANER USE. CONTACTS CLOSE WHEN INDOOR BLOWER IS RUNNING. TERMINALS ARE NOT INTERNALLY POWERED.
- HUM: NORMALLY OPEN CONTACTS FOR OPTIONAL HUMIDIFIER USE. CONTACTS CLOSE WHEN DRAFT INDUCER IS RUNNING. TERMINALS ARE NOT INTERNALLY POWERED.

COLOR CODES:

BK BLACK	GY GRAY	RD RED
BL BLUE	OR ORANGE	WH WHITE
BR BROWN	PK PINK	YL YELLOW
GR GREEN	PU PURPLE	

EQUIPMENT GND

FIELD GND

FIELD SPLICE SWITCH (TEMP.)

IGNITER SWITCH (PRESS.)

OVERCURRENT PROT. DEVICE

LOW VOLTAGE (24V)

LOW VOLTAGE FIELD

HI VOLTAGE (120V)

INTERNAL TO INTEGRATED CONTROL PLUG CONNECTION

JUNCTION

TERMINAL OUTPUT

0140F02646-A

High Voltage: Disconnect all power before servicing or installing this unit. Multiple power sources may be present. Failure to do so may cause property damage, personal injury, or death.

WARNING

MODEL	DESCRIPTION	DM80SN 0403AU*	DM80SN 0603AU*	DM80SN 0604BU*	DM80SN 0804BU*	DM80SN 0805CU*
AFE18-60A	Fossil Fuel Kit	√	√	√	√	√
MVK-01 ¹	Masonry Vent Kit	√	√	√	√	√

¹ Upflow applications only

